



How to build your robot

[www.pib.rocks/build](http://www.pib.rocks/build)



assembly instructions for:

**UPPER BODY**



You  
Print  
Build  
Develop

*your own robot!*

## Printable parts



Pib's upper body consists of **10 different printable parts** (some additional parts for servo assembly are not included in this list, see next page) and is assembled in **14 steps**. We suggest to assemble the upper body at the end of your construction, as the upper body connects everything together and houses the majority of the electrical parts.

In order to construct the upper body, you will need to print the parts as seen in the table.

Please note: For better readability we use the abbreviations in the tutorial: B03 instead of B03-Ripcage\_middle\_left.

### Printable parts

**B03**-Ripcage\_middle\_left

**B04**-Ripcage\_middle\_right

**B05**-Ripcage\_helper\_left

**B06**-Ripcage\_helper\_right

**B08**-Electronics\_back

**B11**-Electronics\_base\_chest

3x **B12**-Electronics\_hinge

**B13**-Servo\_scaffold

**B17**-Ripcage\_middle\_right\_opering

2 x **B14**-Tube\_holder

2 x **B15**-Tube\_holder\_top

## Printable parts



You will also need the following non-printable parts from our pib.Box Master.

If you do not have it yet, you can buy in our shop

<https://shop.pib.rocks>

### Printable parts

3 x **B25**-Wire\_connector\_clockwise

3 x **B26**-Wire\_connector\_pawl\_clockwise

8 x **B27**-Wire\_connector\_mount

3 x **B28**-Wire\_connector\_anitclockwise

3 x **B29**-Wire\_connector\_pawl\_anticlockwise

**B30**-Wire\_connector\_clockwise\_elbow

**B31**-Wire\_connector\_pawl\_clockwise\_elbow

**B33**-Wire\_connector\_anticlockwise\_elbow

**B34**-Wire\_connector\_pawl\_anticlockwise\_elbow

## Non-printable parts



You will also need the following non-printable parts from our pib.Box Master.

If you do not have it yet, you can buy in our shop .

### Non-printable parts - Electronics

1 x **E06**-Power supply

3 x **E03**-Servo\_Bricklet-V2

6 x **E07**-MG996R Servo

2 x **E09**-DS225 Servo

### Non-printable parts

104 x **S01** M3 nuts

12 x **S02** M3 6 mm screws

36 x **S04** M3 10 mm screw

24 x **S06** M3 16 mm screws

14 x **S08** M3 20 mm screws

4 x **S10** M3 25 mm screws

1 x **S11** M3 30 mm screws

4 x **S13** M3 40 mm screws (+ weitere für motorenaufsatz)

3 x **M08** 20 mm metal rods

12 x **M13** M3 Distancer

## Step 1



Connect B05 and B06 using 4 x nuts and 4 x 25 mm screws

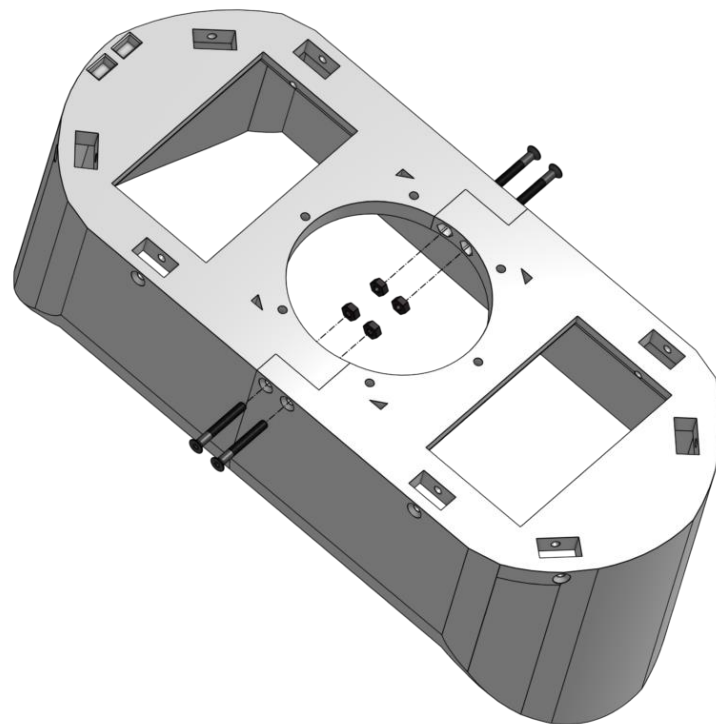
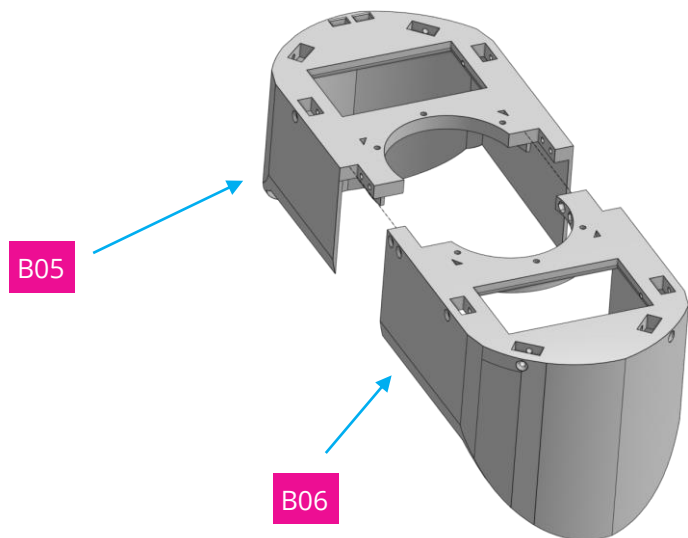

## STEP 2



Connect B05 and B06 using 4 x nuts and 4 x 25 mm screws

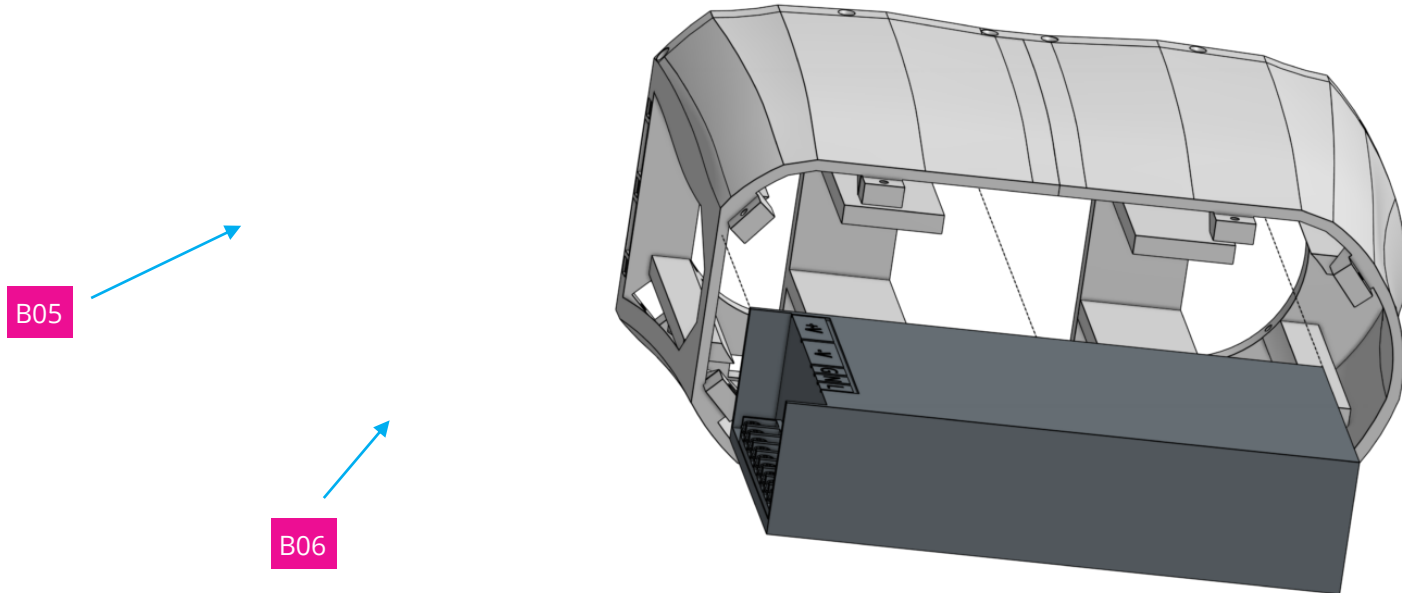

## Step 3



Connect B03 and B04 using 4 x nuts and 4 x 30 mm screws

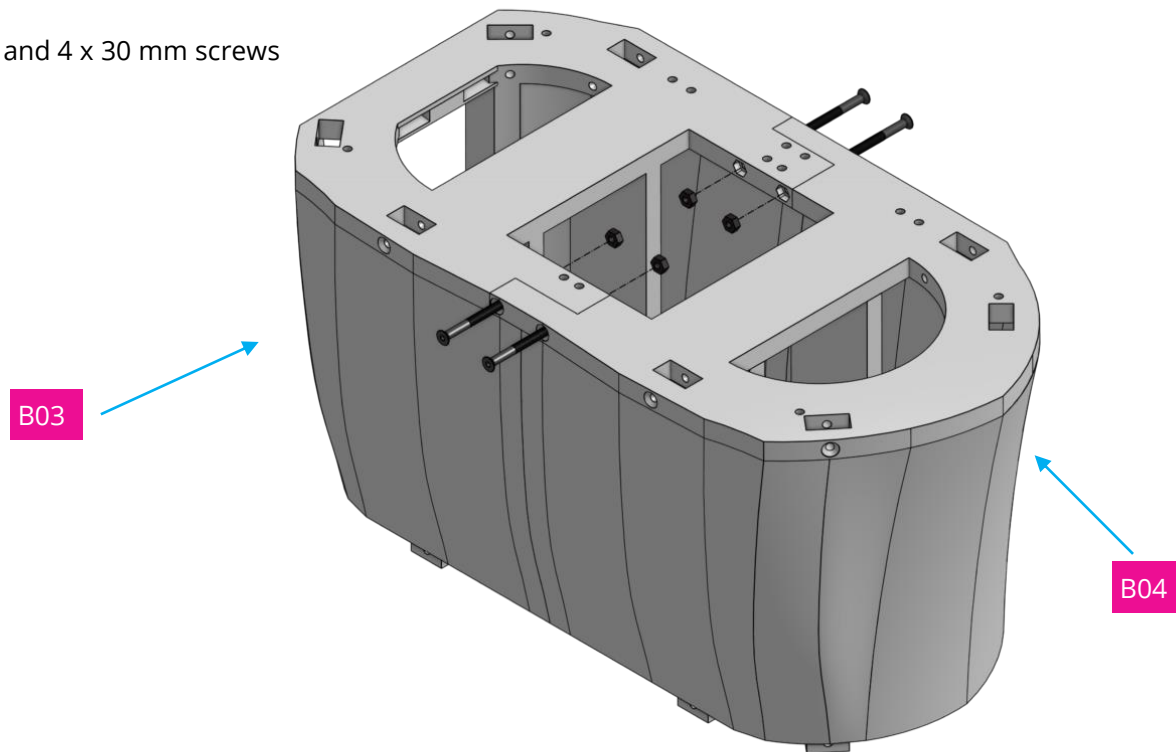

## Step 4a



Connect the assembled B03-B04 with the previous assembled B05-B06 using 8 x nuts and 8x 16mm screws.

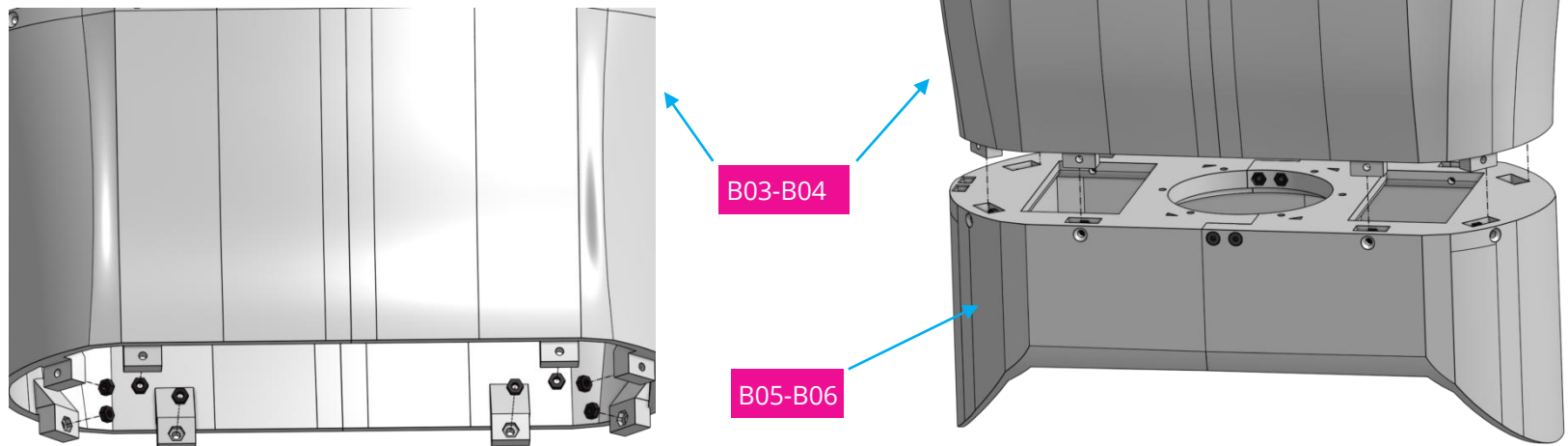



## Step 4b



Connect the assembled B03-B04 with the previous assembled B05-B06 using 8 x nuts and 8x 16mm screws.

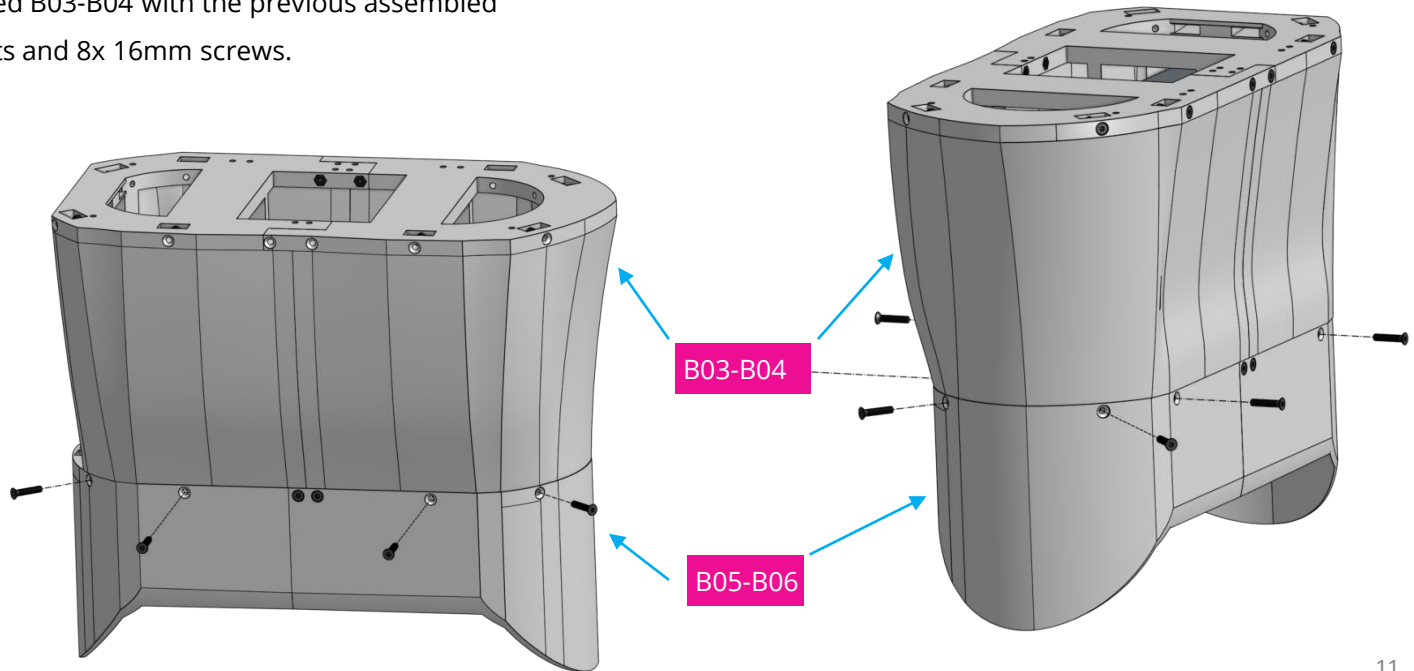

## Step 5



Connect 3 x B12 to the assembly using 2 x nuts and 2 x 20 mm screws for each B12 hinge.

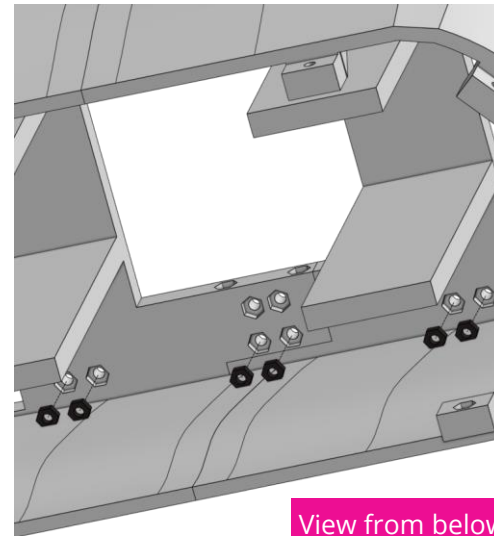
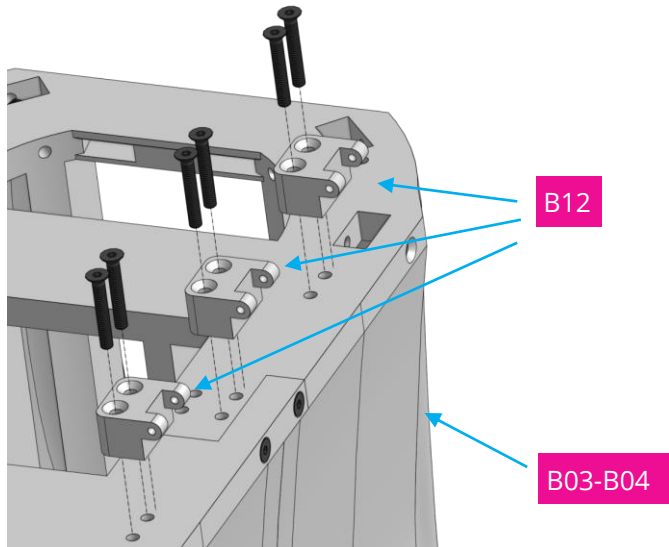

## Step 6



Connect B08 to the 3 x B12 using 3 x metal rods.

Please note: you may need to apply some gentle force at this point to get the metal rod to go in.

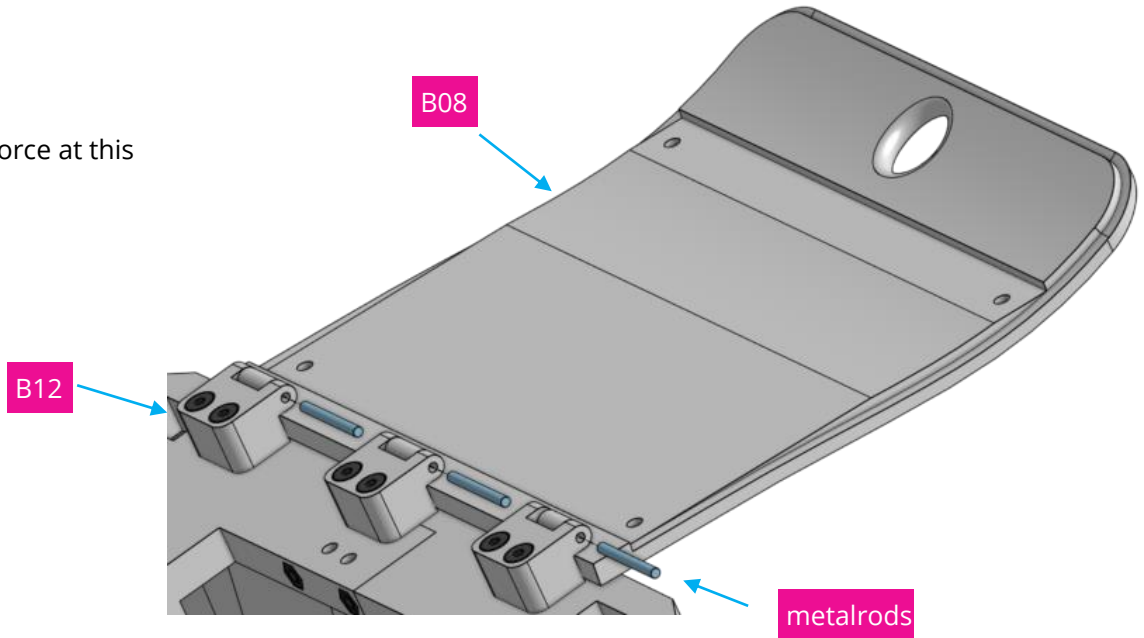

## Step 7a



Connect 3 x Tinkerforge Servobricklet to B11 using 12 x nuts and 12 x 6mm screws and 12 x M3 distancer.

First: Connect 3 Servobricklets with 12 x nuts and 12 x distancer.

B11

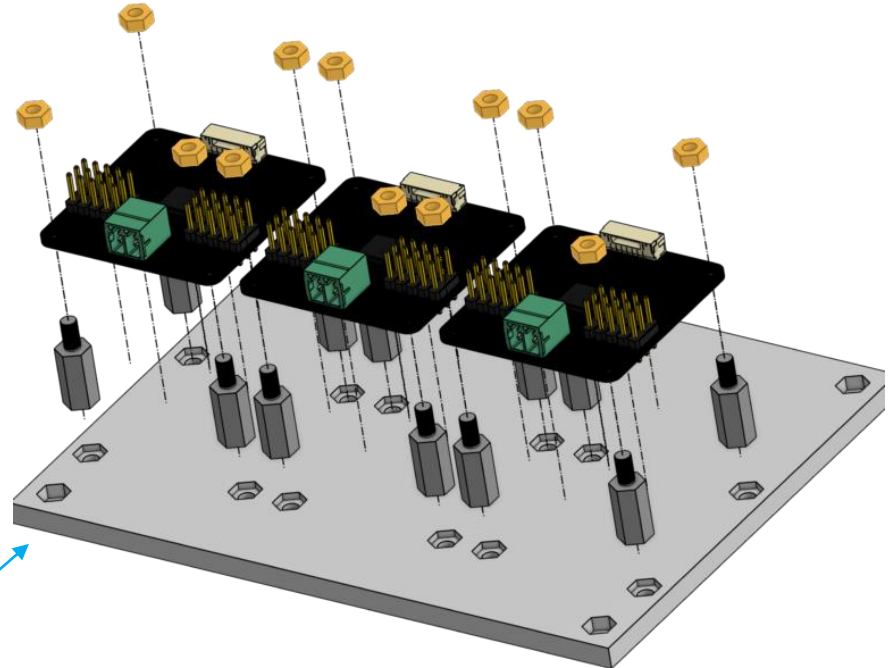

## Step 7b



Second: Connect the assembly to B11 using 12 x 6mm screws

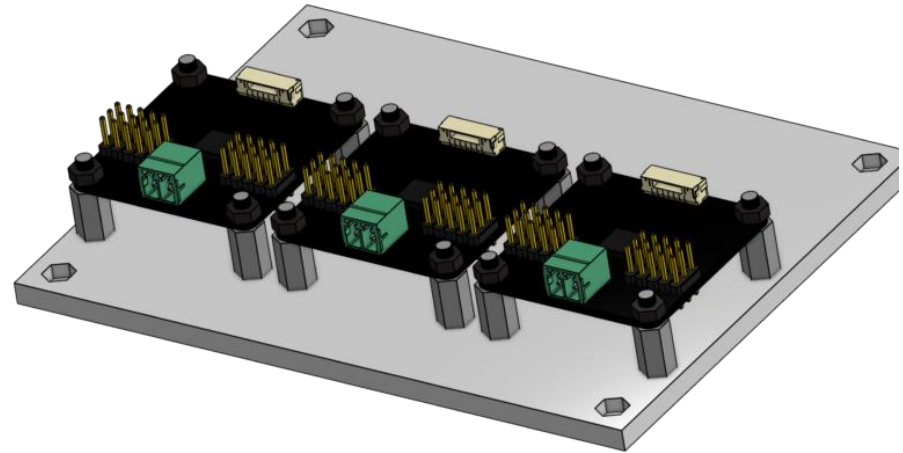
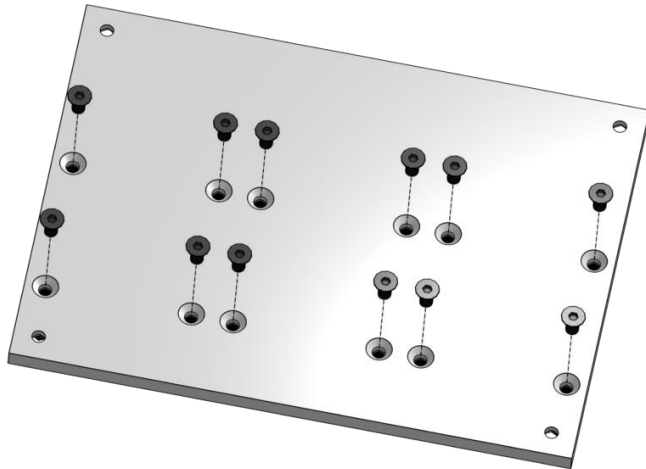

B11 (bottom)

## Step 8



Connect B11 and B08 using 4 x nuts and 4 x 10mm screws.

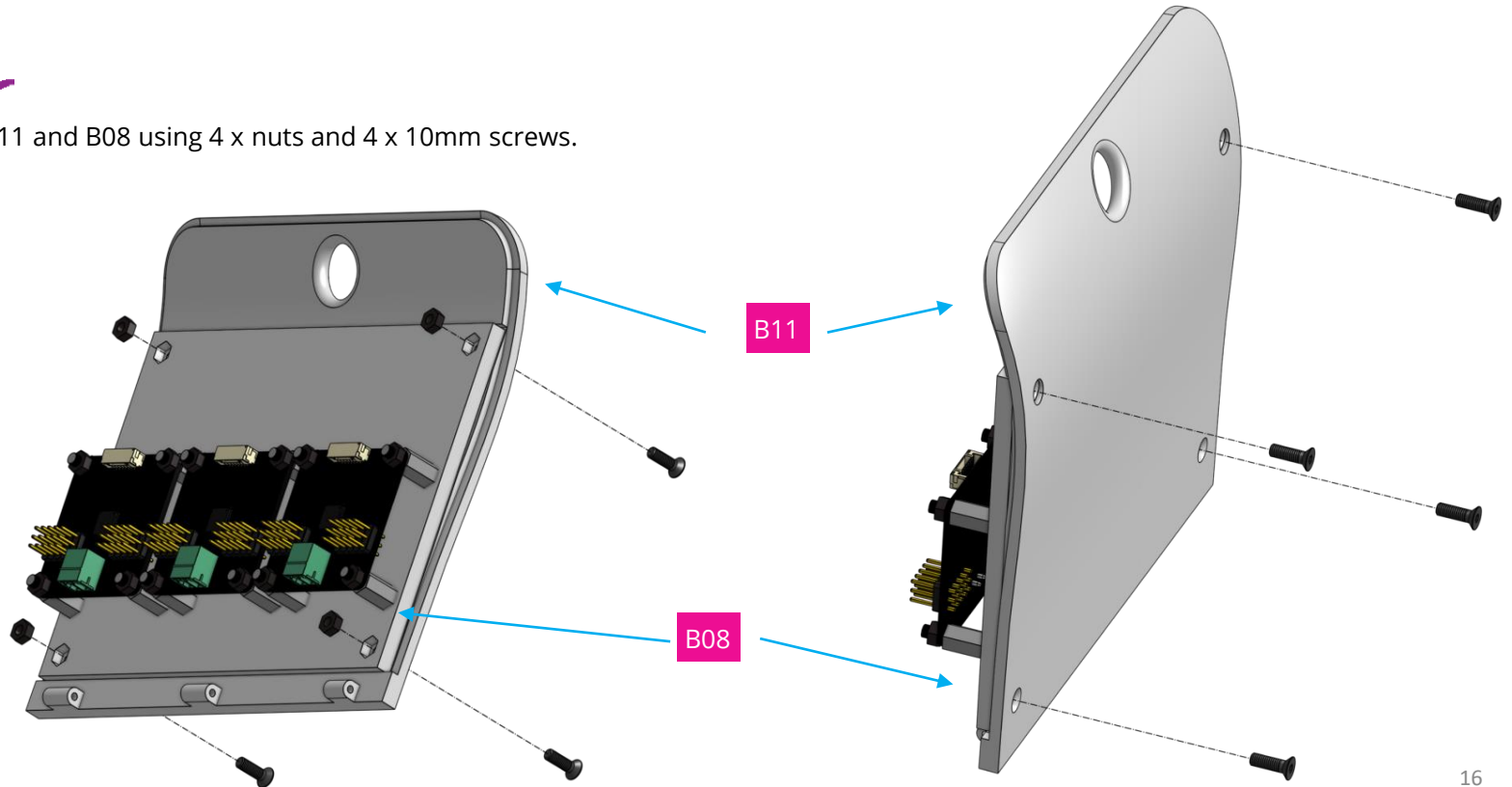

## Step 9



Place 20 x nuts to the shown spots in B13.

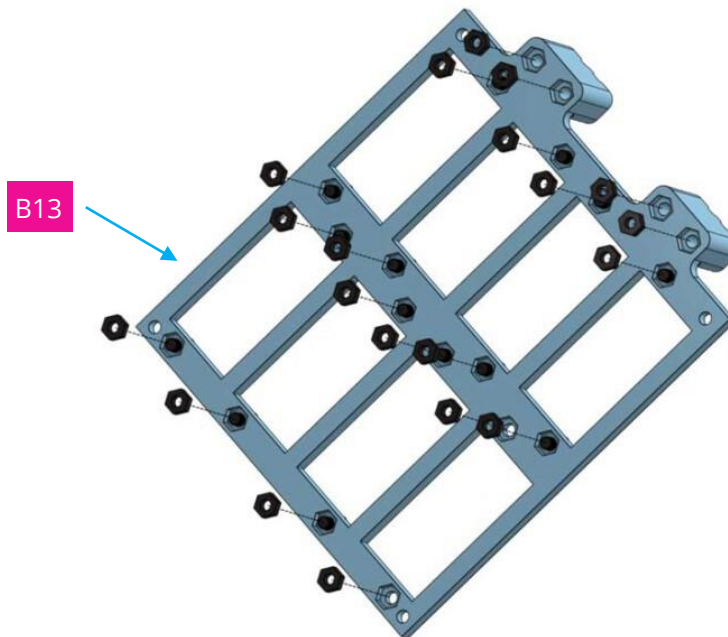

## Step 10



Use 16 x 10 mm screws to connect 6 x E07 and 2 x E09 to B13.

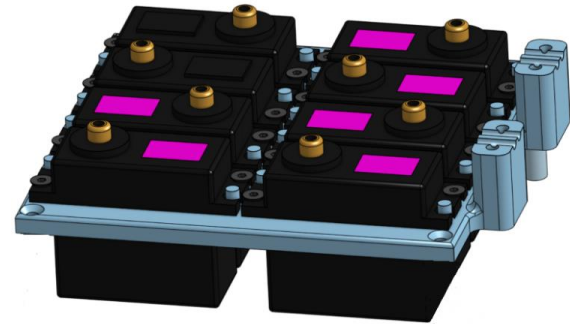
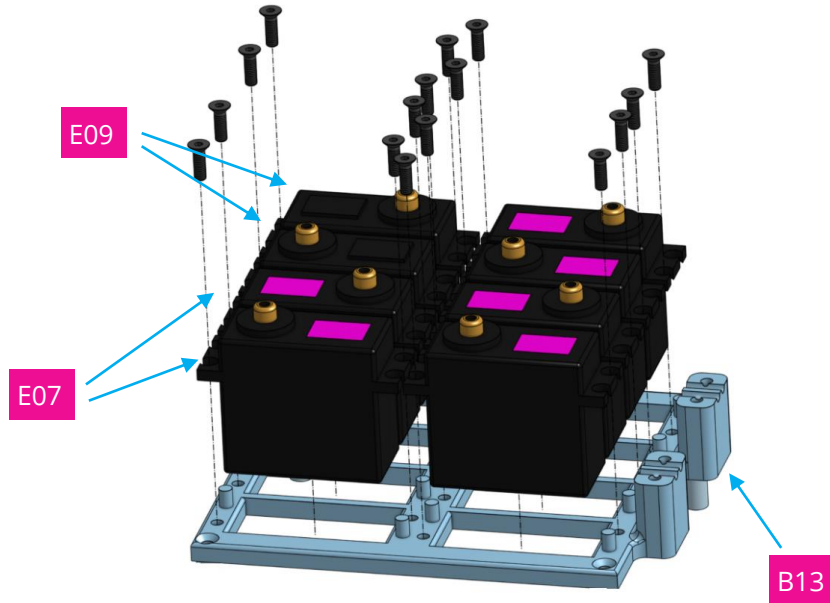



## Step 11



Connect B13 assembly with B16 and then to the ribcage assembly using 4 x nuts and 4 x 40mm screws.

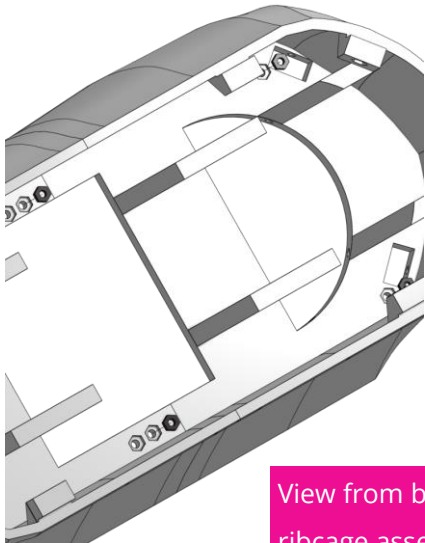

View from below into  
ribcage assembly

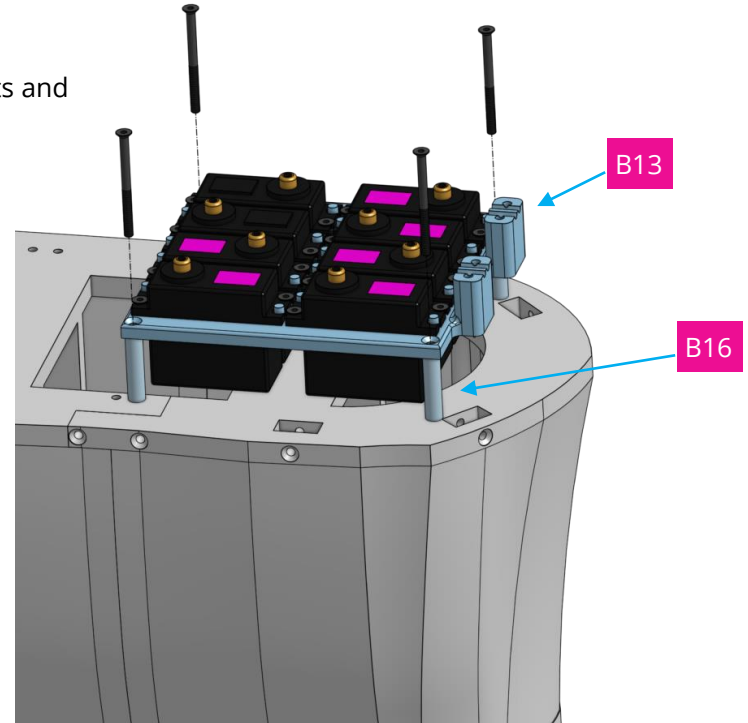

## Step 12



Now, we need to prepare 8 assemblies for wire connectors:

- 1 x Wire\_connector\_elbow-CCW
- 1 x Wire\_connector\_elbow-CW
- 3 x Wire\_connector\_CCW
- 3 x Wire\_connector\_CW

## Step 12



Assemble 3 x **Wire\_connector-CW** using these parts (each 3x)

- **B27**-Wire\_connector\_mount
- **B28**-Wire\_connector\_anitclockwise
- **B29**-Wire\_connector\_pawl\_anticlockwise
- **S06** M3 16mm screw

Assemble 3 x **Wire\_connector-CCW** using these parts (each 3)

- **B27**-Wire\_connector\_mount
- **B25**-Wire\_connector\_clockwise
- **B26**-Wire\_connector\_pawl\_clockwise
- **S06** M3 16mm screw

Assemble 1 x **Wire\_connector\_elbow-CW** using these parts

- **B27**-Wire\_connector\_mount-B27
- **B30**-Wire\_connector\_clockwise\_elbow-B30
- **B31**-Wire\_connector\_pawl\_clockwise\_elbow-B31
- **S06** M3 16mm screw

Assemble 1 x **Wire\_connector\_elbow-CCW** using these parts

- **B27**-Wire\_connector\_mount
- **B33**-Wire\_connector\_anticlockwise\_elbow
- **B34**-Wire\_connector\_pawl\_anticlockwise\_elbow
- **S06** M3 16mm screw

## Step 12



Assemble as shown.

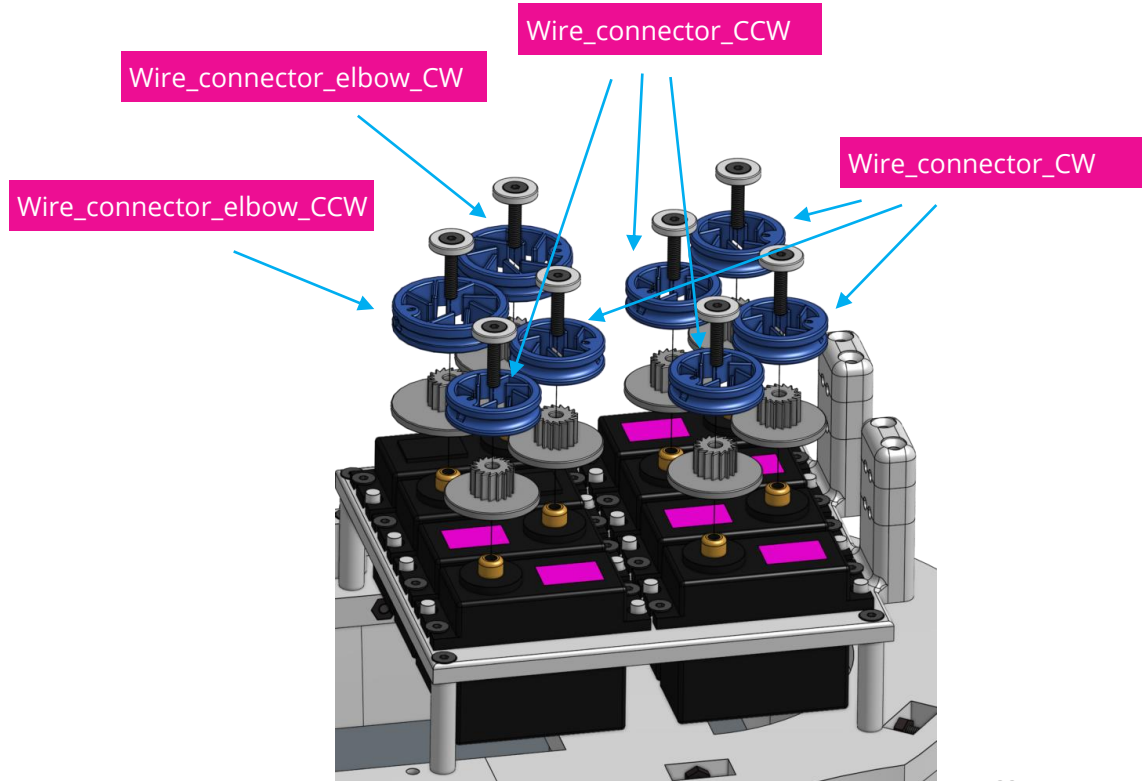
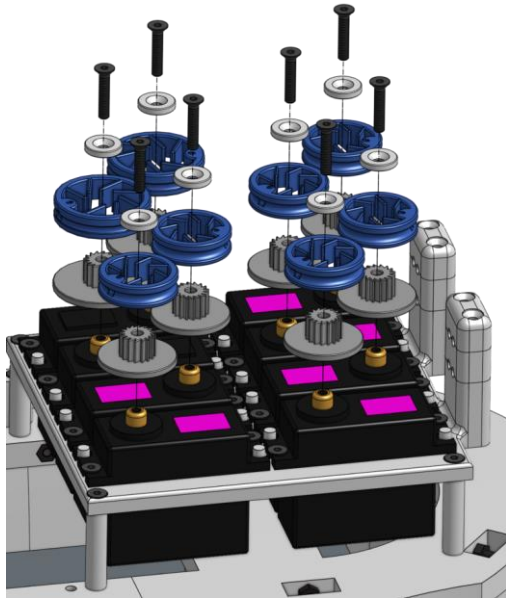

## Step 12



Assemble as shown.

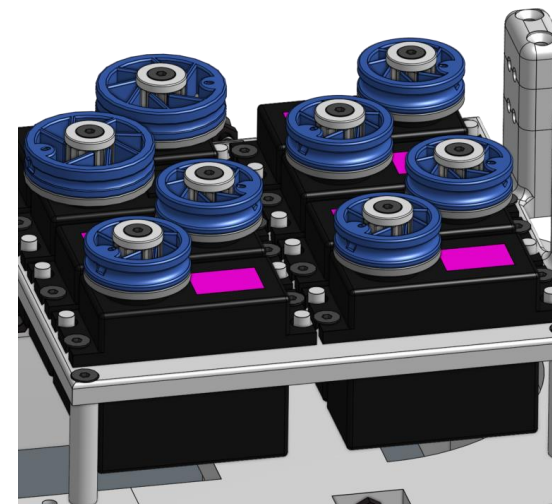
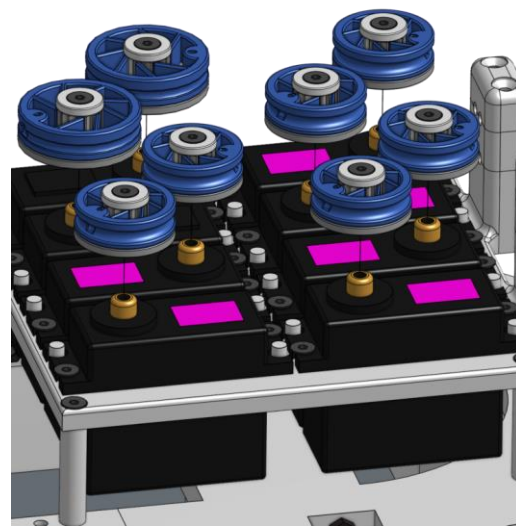
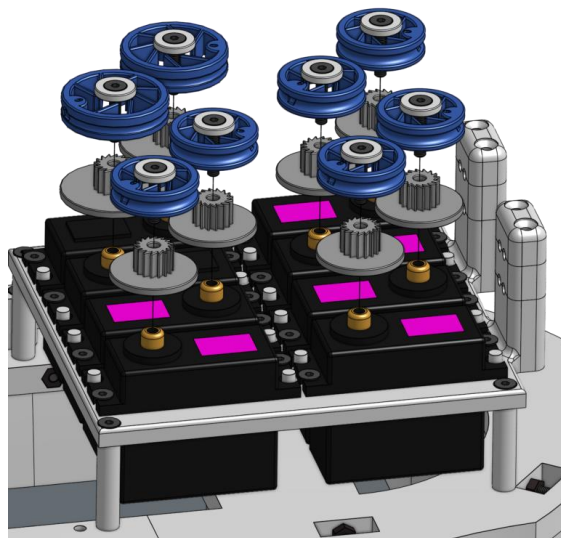

## Step 13



Pass teflon tubes from arm assembly through specified hole in clavicle, hold these tubes on B13, using B14 and B15 and 2 x 40mm screws. Repeat so you have it twice.

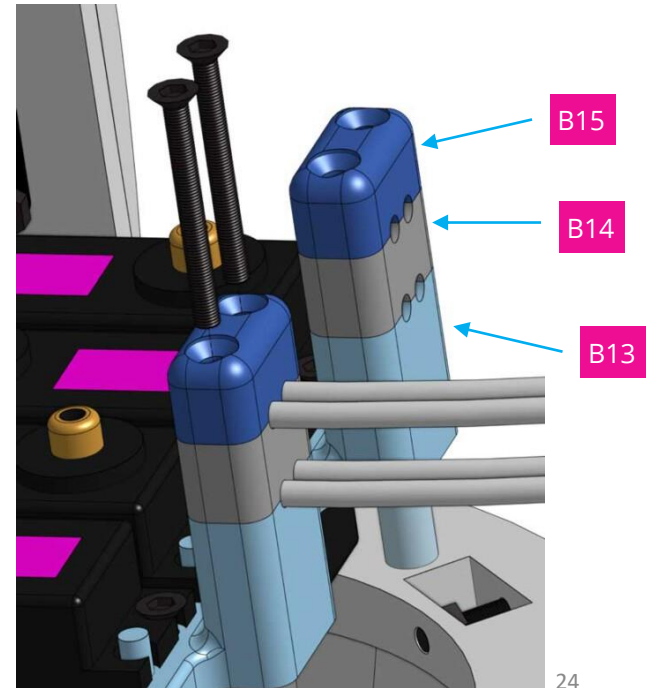
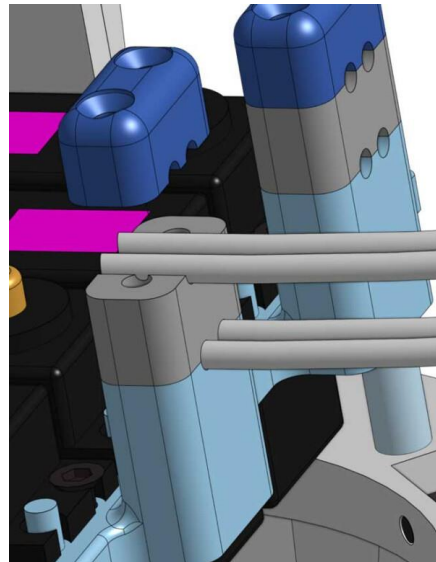
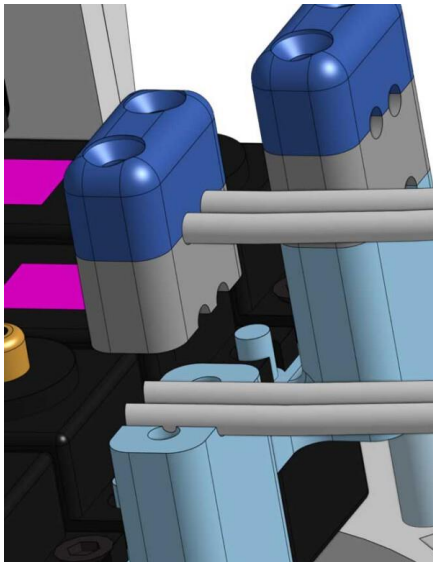

## Step 14



Close ribcage with B17 as shown.

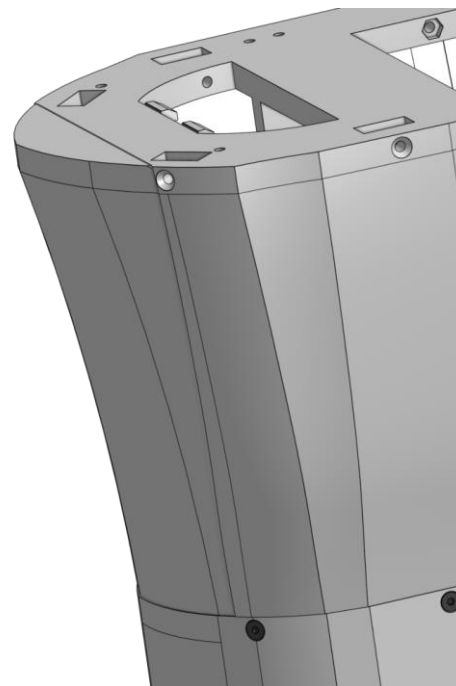
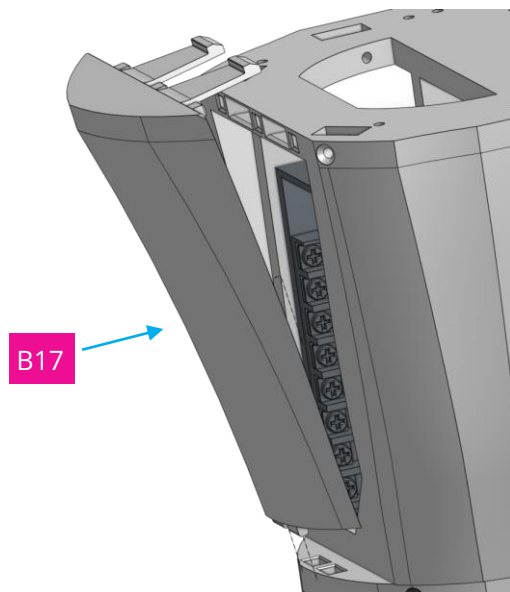

## Do you need support?



Or do you need our pib.Box with all non-printable parts?

Or maybe you have some new ideas and improvements?

Please contact us.



**team@pib.rocks**  
Send us an email.



**discord.com/invite/GRdpyeDu7P**  
Join us on Discord.



**shop.pib.rocks**  
Order non-printable parts for pib.